

ESCORT[®] MAX 4

Owners Manual



AMP UP YOUR AWARENESS
Exceptional Range. AutoLearn™ Intelligence.



INTRODUCTION..... 2

MAX 4 FEATURES 2

PRODUCT SERVICE AND SUPPORT 3

YOUR DEVICE..... 4

WHAT'S IN THE BOX 4

CONTROLS AND FEATURES..... 4

USING MAX 4..... 5

INSTALLATION 6

Drive Smarter® 8

 -DOWNLOAD AND CONNECT TO Drive Smarter® 8

 -CarPlay® and Android Auto® 8

DISPLAY AND MENU 9

UNDERSTANDING YOUR DETECTOR 10

PROGRAMMING MENU 11

TROUBLESHOOTING 22

TRADEMARKS ACKNOWLEDGMENT, WARNINGS, AND REGULATORY INFORMATION..... 23

LIMITED 1-YEAR WARRANTY 24



Congratulations! Your new ESCORT MAX 4 is the most advanced radar/laser detector ever designed. MAX 4 includes 2 LNAs (low noise amplifier) receivers using a dual core processor for exceptional radar detection range and industry-leading false alert filtering for a quieter ride with more accurate alerts. This booklet describes the simple steps for mounting and setting up your detector. It also provides helpful information about how radar and laser guns are used and how you can interpret the alerts you receive. Please drive safely.

MAX 4 FEATURES

- Exceptional Detection Range and Accuracy - MAX 4 includes 2 LNAs (Low Noise Amplifier) receivers using a new dual-core processor for superior radar detection range and false alert filtering.
- Continuously Updated IVT Filter™ - Updatable IVT Filter automatically reduces false alerts from moving In-Vehicle Technology systems such as blind spot monitoring and adaptive cruise control.
- AutoLearn™ Intelligence- location-based intelligence automatically locks out false alerts and allows you to mark locations for future reference.
- Drive Smarter® App - Built-In Bluetooth technology wirelessly connects to the Drive Smarter® app for sharing and receiving radar and laser alerts, red light and speed camera locations, and crowd-sourced alerts.
- Defender Database – MAX 4 includes the pre-loaded Defender Database, an updatable database of verified speed traps, red light and speed camera locations, and more.
- Color OLED Display - Multiple selectable colors to match your vehicle’s lighting.
- Dual Language - English and Spanish voice and text alerts.

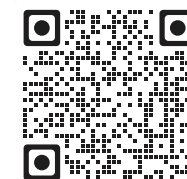

Download
DRIVE SMARTER®





PRODUCT SERVICE AND SUPPORT

For any questions about operating or installing this new Escort product, please contact us first so that we can answer your questions or resolve any issues. Our product support experts will do their best to ensure you are completely satisfied with your product. The contact information for Escort will vary depending on the country in which you purchased and utilize the product. For the latest contact information, please go to www.escortradar.com/support.

WHAT'S IN THE BOX

- MAX 4
- SmartCord® USB
- EZ Mag Mount™
- Carry Case
- Quick Start Guide



CONTROLS & FEATURES



Over Speed Alert Setting



Bluetooth® is connected to smartphone



Speed Limit data from Driver Smarter®, "--" means no data is available

SENSITIVITY MODES

The SEN button selects radar sensitivity/range. The choices are:

Highway – Full sensitivity.

Auto – Reduces X and K band sensitivity based on the speed of the vehicle.

AutoNoX – Same as Auto but without X band detection.

AutoLoK – Same as Auto but with lowered K band sensitivity at all times.

FALSE ALERT FILTERING

MAX 4 is designed to provide you with the most accurate alerts and to minimize the distraction of false alert signals from fixed-location and moving sources.

- **Adjustable Sensitivity:** allows you to adjust detection sensitivity to your driving environment, reducing false alerts from fixed location sources such as automatic door openers. Auto modes automatically adjust detection sensitivity based on your vehicle speed.
- **IVT Filter:** automatically reduces false alerts from moving In-Vehicle Technology sources such as collision avoidance systems and adaptive cruise control.



Using MAX 4

- 1 Plug small end of SmartCord into modular jack on MAX 4 and large end of SmartCord into your vehicle's 12V accessory port.
- 2 MAX 4 should power on automatically. If not, press the device's PWR button.

Software Updates

MAX 4 can only be updated by connecting directly to Detector Tools Pro available at www.escortradar.com/pages/update-your-device. If an update is available, Detector Tools Pro will prompt you to install the update.

Importantly note that Defender database updates require first registering MAX 4 to activate the included 90 day Defender subscription. Defender subscriptions are available at EscortRadar.com.

Using SmartCord USB

- **Mute Button:**
 - Press to mute the audio for a specific alert.
 - Press three times to lock out a false alert.
 - Press twice while receiving a locked-out alert to unlock.
 - When connected to the Drive Smarter® app press and hold the mute button on unit or cord to manually report to other user a verified X or K-band alert, or police office observing traffic.
- **Alert Light:** Blinks red when receiving an alert.
- **Power Light:** Lights green when device is powered on.
- **USB Charging Port:** Charge smartphones, tablets and other USB-charged devices.

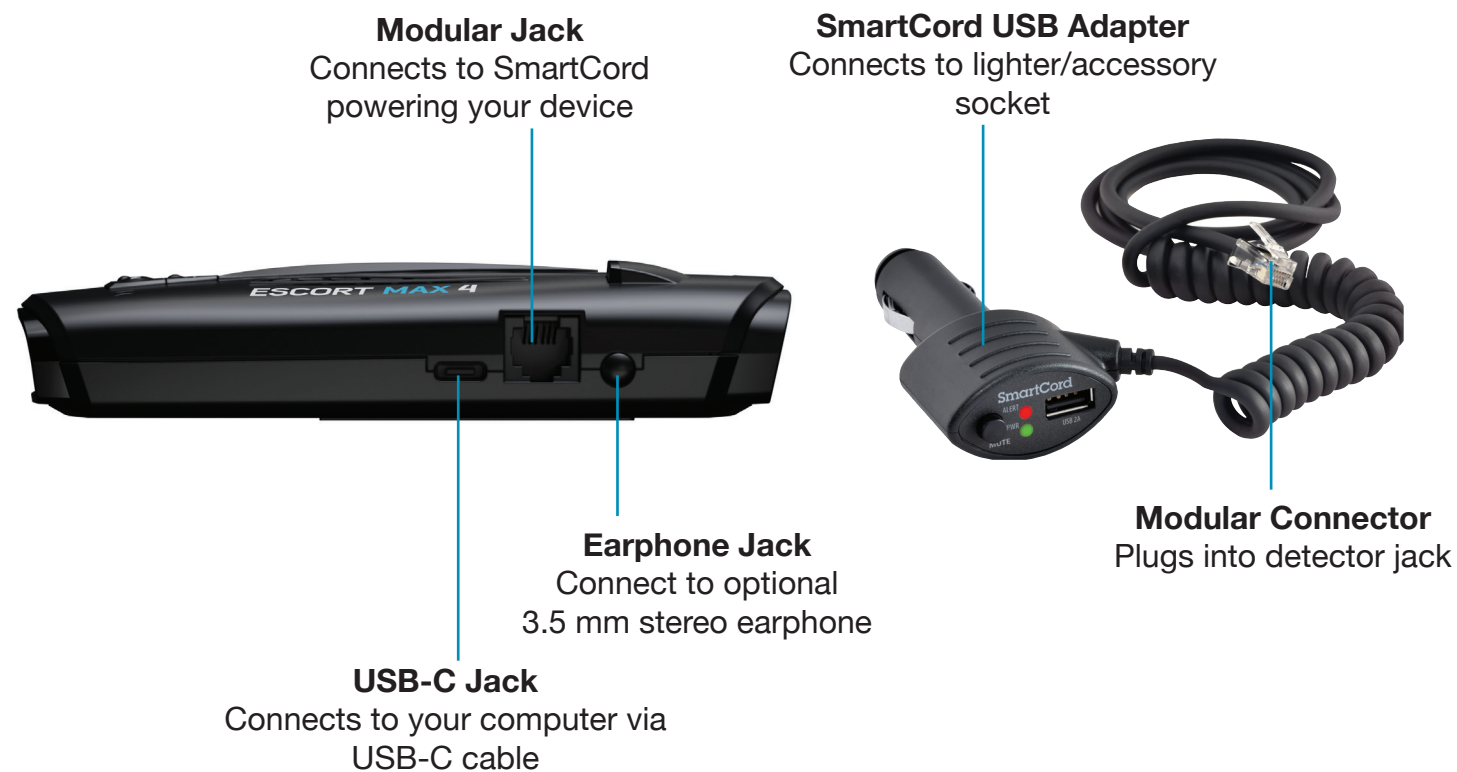

Your new detector comes with our patented EZ Mag Mount™. Simply attach the detector onto the magnetic mounting bracket and ensure it's connected securely. To remove the detector from the mount, simply tilt the detector off of the magnetic mount.

Mounting Tips:

- Center of windshield between driver and passenger.
- Ensure clear view of road ahead and sky above.
- Avoid windshield wipers and heavily tinted areas.

To Mount the Detector in Your Vehicle:

- 1 Remove backing from EZ Mag Mount.
- 2 Firmly press the EZ Mag Mount onto the windshield and flip the locking clamp to secure.
- 3 Tilt the display end of the detector slightly upward and engage with the mounting bracket. The EZ Mag Mount magnet holds the detector firmly in place.
- 4 To adjust view, loosen thumb wheel and adjust angle of mounting bracket. Tighten thumb wheel to secure.
- 5 To remove the detector, simply lift the display end of the detector upward. The detector will fall from the mount.
- 6 To remove the mount from windshield, release the locking clamp and pull the tab on top of the EZ Mag Mount.

EZ Mag Mount Care Instructions:

To clean your EZ Mag Mount, simply rinse under warm water, gently wipe off any debris and allow to air dry.



- 1 Attach EZ Mag Mount™ to MAX 4

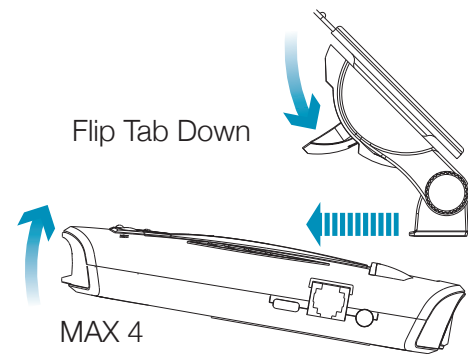

- 2 Mount

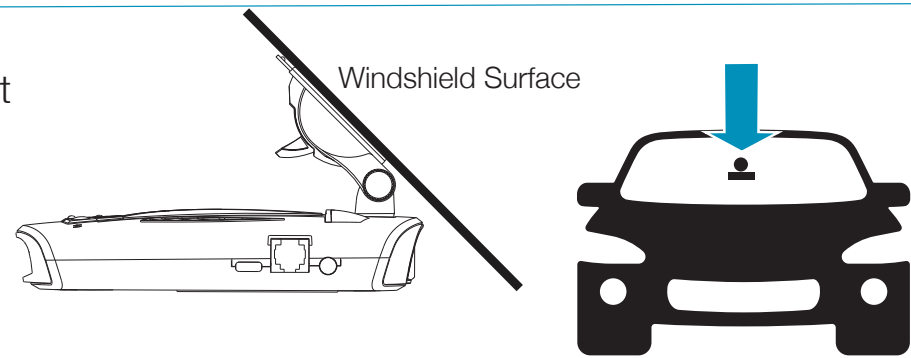

- 3 Lock Mount

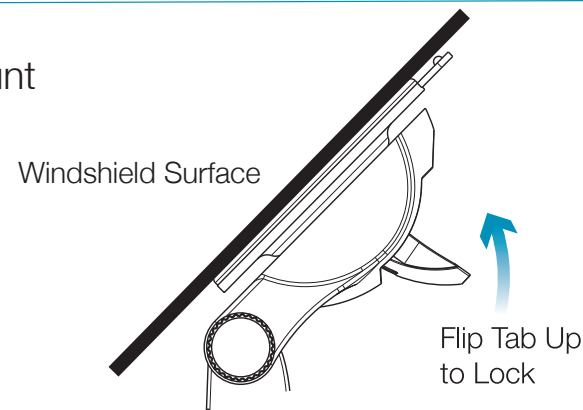

- 4 Connect and Power

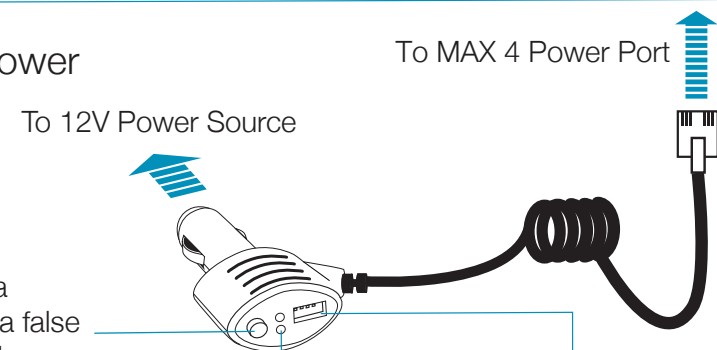

Mute Button

Press to mute the audio for a specific alert, lock or unlock a false alert or manually report to other users a verified X or K-band and other alerts when connected to Drive Smarter®.

Alert & Power LEDs
Blinks red when receiving a radar or laser alert

2A USB Port
Charge smartphones, tablets and other USB-charged devices

DRIVE SMARTER®

Drive Smarter® is the intelligent app you need to make the most of your Escort radar detectors. Available for both iOS and Android smartphones, Drive Smarter allows you to view your route and receive alerts right on your display (see Apple CarPlay below), view a gallery timeline of your M2 dash cam videos, set up advanced safety and security features, and conveniently manage your radar detector settings.

DOWNLOAD AND CONNECT TO DRIVE SMARTER®

- 1 Power on MAX 4.
- 2 Install and run the Drive Smarter® app on your smartphone.
- 3 If you're using Drive Smarter® for the first time, you will be prompted to set up an account.
- 4 Fill in your account information within the "Create Account" screen and click "Register".
- 5 A message will be sent to the email address specified in your account set up, which will verify your new account.
- 6 Be sure Bluetooth® is actived on your smartphone. In the Drive Smarter® app, press the Account button then select "Add devices".
- 7 Follow the prompts in the Drive Smarter® app to connect MAX 4.

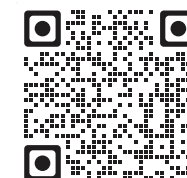
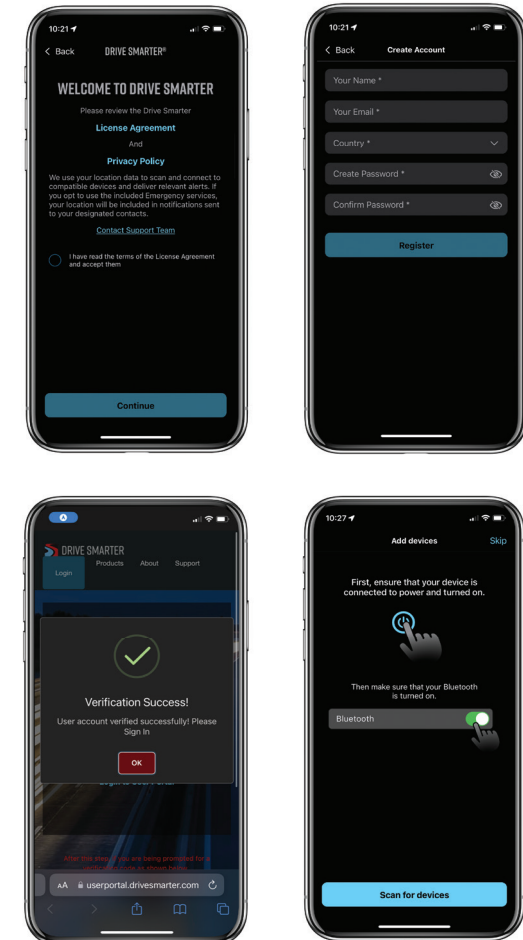

Download
DRIVE SMARTER®

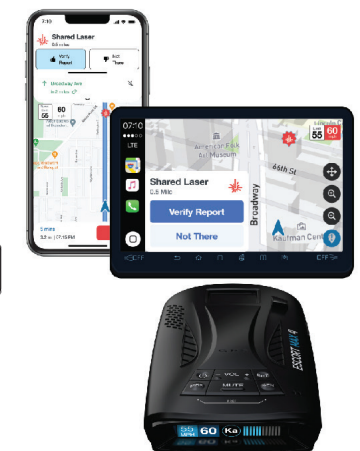

DISPLAY AND MENU

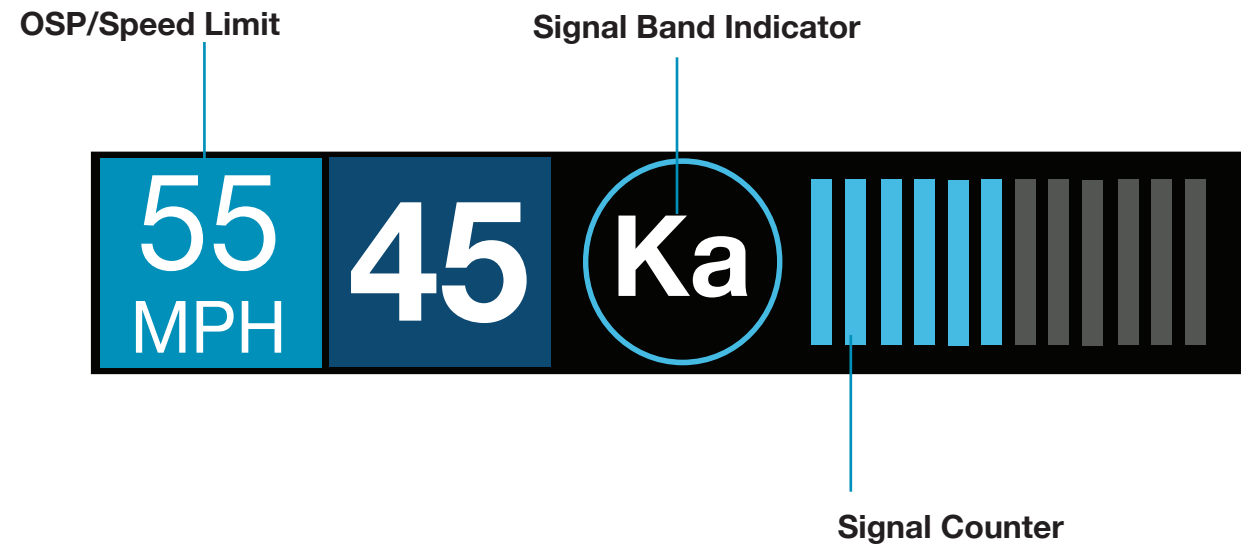

- Signal Band Indicator**
 Displays the radar band of the alert:
 - X Band (commonly false alerts).
 - K band (used by police radar and false alerts)
 - Ka band (almost always police radar)
 - Laser (almost always police)
- Signal Strength Meters**
 Displays the signal strength, or how close, the alert is. The more alert bars displayed, the stronger the signal strength. The left meter is front signal strength. The right meter is rear signal strength.
- OSP/Speed Limit Indicator**
 Over Speed alert setting, can be adjusted in the Programming menu. Bluetooth icon will appear here when paired to phone. Speed limit data will appear here when connected to the Drive Smarter app via Bluetooth®.
- Signal Counter**
 Displays the number of alerts being detected.
- Speed**
 Displays the current speed. When Speed Display is off, displays the vehicle voltage.

UNDERSTANDING YOUR DETECTOR

How Radar Works

Traffic radar, which consists of microwaves, travels in straight lines and is easily reflected by objects such as cars, trucks, even guardrails and overpasses. Radar works by directing its microwave beam down the road. As your vehicle travels into range, the microwave beam bounces off your car, and the radar antenna looks for the reflections.

Using the Doppler Principle, the radar equipment then calculates your speed by comparing the frequency of the reflection of your car to the original frequency of the beam sent out.

Traffic radar has limitations, the most significant of these being that it typically can monitor only one target at a time. If there is more than one vehicle within range, it is up to the radar operator to decide which target is producing the strongest reflection. Since the strength of the reflection is affected by both the size of the vehicle and its proximity to the antenna, it is difficult for the radar operator to determine if the signal is from a sports car nearby or a semi-truck several hundred feet away.

Radar range also depends on the power of the radar equipment itself. The strength of the radar unit's beam diminishes with distance. The farther the radar has to travel, the less energy it has for speed detection.

Because intrusion alarms and motion sensors often operate on the same frequency as X, and K-band radar, your detector will occasionally receive non-police radar signals. These transmitters generally produce much weaker readings than will a true radar encounter. As you become familiar with the sources of these pseudo alarms in your daily driving, they will serve as confirmation that your device's radar detection abilities are fully operational.

How Laser (Lidar) Works

Laser speed detection is actually light detection and ranging (LIDAR). Laser guns project a beam of invisible infrared light. The signal is a series of very short infrared light energy pulses that move in a straight line, reflecting off your car and returning to the gun. Laser uses these light pulses to measure the distance to a vehicle. Speed is then calculated by measuring how quickly these pulses are reflected, given the known speed of light.

Laser is a newer technology whose use is not as widespread as conventional radar; therefore, you may not encounter it on a daily basis. And unlike radar detection, laser is not prone to false alarms. Because laser transmits a much narrower beam than does radar, it is much more accurate in its ability to distinguish between targets and is also more difficult to detect. As a result, even the briefest laser alert should be taken seriously.

There are limitations to laser, however. Laser is much more sensitive to weather conditions than radar, and a laser gun's range will be decreased by anything affecting visibility, such as rain, fog or smoke. A laser gun cannot operate through glass, and it must be stationary to get an accurate reading. Because laser must have a clear line of sight and is subject to cosine error (an inaccuracy that increases as the angle between the gun and the vehicle increases), police typically use laser equipment parallel to the road or from an overpass. Laser can be used day or night.

TSR Signal Ranking Software

Your radar detector includes an optional boost in anti-falsing software to eliminate excessive alerts from erroneous K-band sources. One example of this is traffic flow monitoring systems. These systems, which are becoming more widely used in several countries, generate K-band signals to measure the flow of traffic on a given road. Unfortunately most detectors see this as a real threat and will alert you to it unnecessarily. Our proprietary TSR software, intelligently sorts, ranks and rejects this type of false alarm automatically. The result is ultimate protection without excessive false alarms.



PROGRAMMING MENU

Overview

To access the programming menu, press the SEN and MRK buttons. Press the MRK button to change the selected menu item. Use the - or + button to change the setting on the selected menu item. Press the MRK button again to return to the selected Menu item.

To exit Programming, simply wait a few seconds without pressing any buttons. A “Completed” message will display, confirming your selection(s).

Restore Factory Settings

To restore MAX 4 to its original factory settings:

- Press and hold SEN and BRT while turning the power on.
- Factory Settings Restored will display and MAX 4 will reboot.

The following is a list of all settings available in the Programming menu followed by detailed descriptions of each setting.



User Mode	Advanced* Novice	Access and customize all Settings and Preferences Access and customize Units and Display Color only, (all other Settings are set to factory defaults) <i>NOTE: Switch back to Advanced Mode to view all Preferences.</i>
Pilot Mode	Scanning* Full Word	Display scanning bar and the selected SEN mode Displays only the selected SEN mode
Display Color	Blue*/Green/Red/Amber	Set color to match your vehicle’s dash display
Speed Display	On* Off	Displays current speed Displays battery voltage
Cruise Alert	20 mph* Off/20-160 mph	Offers only double beep alert tones below the specified speed
Over Speed	70 mph* Off/20-160 mph	Alerts when the specified speed is exceeded
Meter Mode	Standard* Spec Expert Simple	Displays primary alert band with front signal strength bar graph Displays primary alert band with numeric frequency and only front signal strength bar graph Displays up to four alert bands with front and rear signal strength bar graphs for each Simple messages replace alert band and signal strength bar graphs: Caution (if traveling below Cruise Alert limit) Slow Down (if traveling above Cruise Alert limit)



Operation

Tones	Standard*	Standard alert tones
	Standard+	Standard alert tones for primary alert plus a double-beep tone for additional alerts
	Mild	Mild doorbell chime alert tones
AutoMute	Low / Med* / High / Off	During an alert, automatically reduces audio to selected volume level
AutoLearn	On* / Off	Automatically stores and locks out false alerts
Units	English* / Metric	Units for distance and speed
Language	English* / Español	Language for voice and text
Voice	On* / Off	Voice announcements
GPS Filter	On* / Off	Enables GPS Filtering of stored false alerts
AutoPower	Off / 1 Hour / 2 Hours / 4 Hours* / 8 Hours	Powers down unit after specified time <i>NOTE: If AutoPower is enabled, to save screen life the display screen goes blank after 30 minutes without moving. Display screen will turn on automatically after you reach 10MPH</i>
Band Enables	Default* Modified	Default Band Enables Band Enables have been modified from their default settings
Repeatedly press BRT to cycle through Band Enables. Press + or – to change the selected Band Enable on or off		
X Band	On* / Off	
K Band	On* / Off	Covers frequency range: 24.050 – 24.250 GHz <i>NOTE: When K Band is off, K Narrow bands are available selections</i>
K Narrow 1	On* / Off	Covers frequency range: 24.050 – 24.110 GHz
K Narrow 2	On* / Off	Covers frequency range: 24.110 – 24.175 GHz
K Narrow 3	On* / Off	Covers frequency range: 24.175 – 24.250 GHz
K Narrow 4	On / Off*	Covers frequency range: 23.950 – 24.050 GHz
MultaRadar CD	On / Off*	MultaRadar CD detection
MultaRadar CT	On / Off*	MultaRadar CT detection



Operation

Ka Band	On / Off*	Covers frequency range: 33.400 – 36.000 GHz <i>NOTE: When Ka Band is off, Ka Narrow bands are available selections</i>
Ka Narrow 1	On / Off*	Covers frequency range: 33.400 – 33.700 GHz
Ka Narrow 2	On* / Off	Covers frequency range: 33.700 – 33.900 GHz
Ka Narrow 3	On / Off*	Covers frequency range: 33.900 – 34.200 GHz
Ka Narrow 4	On / Off*	Covers frequency range: 34.200 – 34.600 GHz
Ka Narrow 5	On* / Off	Covers frequency range: 34.600 – 34.800 GHz
Ka Narrow 6	On / Off*	Covers frequency range: 34.800 – 35.160 GHz
Ka Narrow 7	On / Off*	Covers frequency range: 35.160 – 35.400 GHz
Ka Narrow 8	On* / Off	Covers frequency range: 35.400 – 35.600 GHz
Ka Narrow 9	On / Off*	Covers frequency range: 35.600 – 35.840 GHz
Ka Narrow 10	On / Off*	Covers frequency range: 35.840 – 36.000 GHz
Laser	On* / Off	Laser detection
TSR	On* / Off	Traffic Sensor Rejection (TSR) filtering
Exit		Exit Band Enables menu
K Notch	On / Off*	Reduces sensitivity of K band frequency range: 24.190 – 24.210 GHz <i>NOTE: K Notch is effective at reducing alerts to certain vehicle collision avoidance systems</i>
Shifters	Receive / Shift* / Shift4 / Shift6 / Shift8 / Shift10 / Off	Shifter mode. Receive = receive-only Shift4/6/8/10 puts shifters in receive-only mode after 4/6/8/10 seconds from receiving an alert <i>NOTE: only available when optional ZR5 or ZW5 shifters are connected</i>
Marker Enable	Default* Modified	Default Marker Enables Marker Enables have been modified from their default settings

Repeatedly press BRT to cycle through Marker Enables. Press + or – to change the selected Marker Enable on or off

Other	On* / Off	Other location
Red light	On* / Off	Red light camera
Red & Speed	On* / Off	Red light and speed camera
Speed Camera	On* / Off	Speed camera
Speed Trap	On* / Off	Speed trap
Air Patrol	On / Off*	Aircraft enforcement areas
Exit		Exit Marker Enables menu

Clear Location	Marked*	Clear all user marked locations
	Lockouts	Clear all locked out false alerts
	Defender	Clear all Defender locations
	Format	Clears all locations Press BRT twice to confirm selection

Interface	Mode 1* / Mode 2	Default is "Mode 1"
-----------	------------------	---------------------

Serial Number and Software Version

To view your MAX 4's serial number and software revision, press and hold the MRK and MUTE buttons while powering on the detector.

User Mode

Advanced Access and customize all settings and preferences.

Novice Access and customize only Units (English or metric) and Display Color. All other preferences are set to factory defaults. To view all settings and preferences, you must switch to Advanced mode.

Display Color

The display graphics can be changed to blue, green, red or orange to match the instrument lighting of your vehicle.

Speed Display

Turns Speed Display off or on. When Speed Display is off, the vehicle's voltage is displayed.

Cruise Alert

While traveling below the set Cruise Alert speed, all alerts sound a short double beep. The alert will fully sound when you exceed the Cruise Alert speed.

Over Speed

You can set the Over Speed alert to notify you when you are traveling over a specified speed. When you travel above the speed that you have set, the background display for your current speed will turn red and a voice prompt will announce "Over Speed".

When connected to the Drive Smarter app, the Over Speed setting is automatically set to the speed limit showing on the display. If no speed limit data is available and the display shows --, the Over Speed setting is used.

Over Speed Limit

NOTE: this setting only applies when MAX 4 is connected to Bluetooth® with internet connectivity.

When the speed limit is exceeded by the set speed, the background for your current speed will change to red and a voice prompt will announce "Over Speed". If no speed limit data is available and the display shows --, the Over Speed setting is used.

Meter Mode

MAX 4 offers five different settings for displaying information about alerts.

Standard

The Standard meter mode provides only the band information and front signal strength information of a single alert. When radar is detected, the band (X, K or Ka) and a bar graph of the signal's strength are displayed. When laser is detected, the display will simply read "Laser." If there are multiple alerts present, only the highest priority threat is displayed. Laser is the highest priority threat, followed by Ka, K, then X band radar.

Spec

The Spec meter option is an advanced display for experienced detector users. In this mode, it will display the actual numeric radar frequency being received. Even long-time detector users will require some time to get familiar with this new level of information about detected signals. To use Spec instead of the Standard bar graph meter, you must select it (Spec) in Preferences.

Expert

ESCORT's exclusive Expert meter option is designed for the advanced detector user. In this mode, MAX 3 simultaneously tracks up to four radar signals. It shows each band along with a bar graph of its signal strength. In the image above, a Ka band, K band and two X bands are being detected with the greyed-out X band being a locked out false. Expert meter mode can help you spot a change in your normal driving environment (e.g., a traffic radar unit being operated in an area where there are normally other signals present).

Simple

Simple messages replace bands and signal strengths or frequencies:

Caution used when an alert is received while you are traveling below your current Cruise Alert setting (or posted speed limit for your current location when connected to Drive Smarter).

Slow Down displayed when an alert is received while you are traveling above the current Cruise Alert setting (or posted speed limit of your current location, when connected to Drive Smarter).

Tones

Standard

The factory default Standard alert tones uses a Geiger counter-type sound to indicate the signal strength and type of radar signal being encountered. When you encounter radar, a distinct audible alert will sound and will increase as the signal gets stronger. This allows you to judge the distance from the signal source without taking your eyes off of the road. Each band has a distinct tone for easy identification:

X band = beep tone

K band = brap tone

Ka band = double-brap tone Laser = solid brap tone

POP = solid brap tone

Standard Plus

Features the Standard alert tones outlined above for the primary alert, plus double-beep tones for additional alerts.

Mild

Mild alert tones offer softer, simpler alert tones that are less obtrusive to the driving experience:

X band, K band, Ka band and POP = Doorbell chime

Low signal strength = Double chime

High signal strength = Triple chime

If alert remains in area more than 15 seconds = Single chime (as a reminder)

Laser = Solid brap tone

Since laser signals are a possible threat no matter how weak, laser alerts are always full strength.

AutoMute

Your MAX 4 also includes ESCORT’s patented AutoMute feature. Once MAX 4 alerts you to a radar encounter at your selected volume level, it automatically reduces the volume to the selected AutoMute level. This keeps you informed without the annoyance of a continuous full-volume alert. If you prefer, you can turn the AutoMute feature off.

AutoLearn™ Intelligence

The AutoLearn feature analyzes (over time) the source of radar signals by location and frequency. This allows MAX 4 to determine if a fixed location signal is a real threat or a false one. If it determines that the signal is an automatic door opener, motion sensor, etc., it automatically locks out this source at this particular location. A “Stored” message will appear on the display when a signal has been automatically locked out. AutoLearn needs to encounter the exact frequency in the same location approximately three times to lock it out. Since some door openers are turned on and off routinely, some variations may occur. Variations may also occur with seasonal temperature changes that can affect the frequency that these radar sources transmit.

MAX 4 will also unlearn signals to protect you from locking out real threats. If a particular signal is no longer present at a location that was previously locked out, MAX 4 will unlock that signal. If you prefer, you can turn the AutoLearn feature off.

GPS Filter (TrueLock)

MAX 4 is equipped with a TrueLock GPS Filter to store and lock out, or ignore, fixed location false alerts in its memory. Common sources of fixed location false alerts are storefront automatic door openers and motion sensors. The TrueLock GPS Filter will not lock out moving false alerts that are commonly caused by vehicle’s blind spot monitoring and collision avoidance systems.

Locking Out False Alerts

To manually lock out a fixed location false alert (X band, K band or laser only), press the MUTE button three times during an alert. Pressing the first time will silence the audio. Pressing a second time will generate a prompt on the display that will read “Lockout?” Press a third time to confirm you want to lock this signal out by location and frequency. A “Stored” message will be displayed. Once a signal has been stored, MAX 4 will not audibly alert the next time you approach this area but will display the locked-out alert in grey.

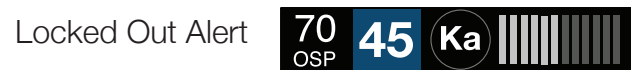

To unlock a signal that has already been stored, simply press the MUTE button twice while receiving the locked out alert. The display will read “Unlock?” when pressing MUTE the first time. Press the MUTE button again to unlock it from memory. The display will read “Unlocked” to confirm your action.

NOTE: When the GPS Filter is set to OFF, you do not have access to MAX 4’s other GPS- enabled features (e.g., Defender Database alerts, marking locations, etc.).

AutoPower

This feature automatically turns off MAX 4 after a set period of time to save unnecessary drain on your battery. This is especially useful if your vehicle has a constant-power ignition. To turn MAX 4 on again you must press the power button.

NOTE: If AutoPower is on, to save screen life the display screen goes blank after 30 minutes without moving. The display screen will turn on automatically after you reach 10MPH.

Band Enables

In the factory default setting the suggested radar and laser bands for North America are monitored and sources of some common false alerts are rejected. It is highly recommended that you use your MAX 4 in this mode.

If you modify Band Enables then this setting will show Modified. The MAX 4 will also notify you during the startup sequence with an audible alert.

WARNING: Do not turn off any Band Enables unless you are absolutely certain there are no traffic radar guns in your area using that specific band.

K Notch

Reduces sensitivity of K band in the frequency range of 24.190 – 24.210 GHz. This is effective at reducing alerts to certain vehicle collision avoidance systems.

Shifters (only available when optional ZR5 or ZW5 laser shifters are connected)

Sets the shifter mode of operation. Receive = receive-only mode. Shift4/6/8/10 puts the laser shifters into receive-only mode after 4/6/8/10 seconds from receiving an alert. After 30 seconds of not receiving a Laser alert, the shifters automatically return to shift mode. You can also manually put the laser shifters into receive-only mode by double tapping the Mute button on the detector or SmartCord.

Marker Enables

MAX 4 gives advanced warning of upcoming markers at the following distances:

Red light cameras	250 ft or 10 seconds
Red light & speed cameras	250 ft or 10 seconds
Speed cameras	500 ft when traveling below 55 mph 1,000 ft when traveling above 55 mph
Speed traps	0.3 mi or approximately 1,584 ft
Other	500 ft when traveling below 55 mph 1,000 ft when traveling above 55 mph



To Mark A Location

- Press MRK. The display will read “Mark?” Press MRK again to bring up a menu of markers to choose from.
- Use the plus and minus buttons to scroll through the markers then press MRK to select the marker that you wish to use at this location.
- The display will read “Marked!”

Air Patrol locations cannot be marked by the user.

NOTE: When a location is marked the first time, you must travel at least 1 mile away from that location to receive an alert when you return to the area.

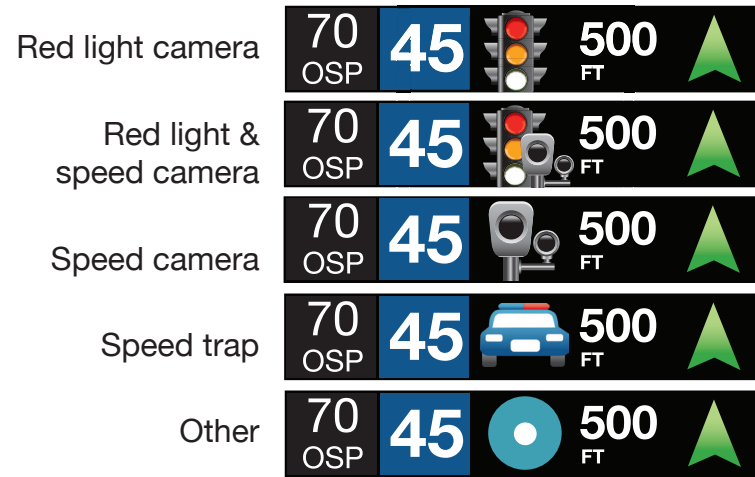

To Unmark A Location

Touch the MRK button when you are receiving a marked-location alert. The display will read “Unmark?” Touch the MRK button again to confirm. The display will read “Unmarked!”

Clear Locations

At some point, you may wish to clear some of the data in MAX 4’s database. This may include any of the following: Defender Database data, Marked locations or false alert Lockouts.

To clear locations in the selected database, select the database then press MUTE to confirm. Format clears locations in all databases.



PROBLEM

SOLUTION

Detector beeps briefly at the same location every day, but no radar source is in sight.

A motion sensor or intrusion alarm is located within range of your route. If you have AutoLearn enabled, the factory default setting, then MAX 4 will store this signal after about 3 passes and no longer alert to it.

Detector did not alert when a police car was in view.

Officer may not have radar or laser unit turned on. VASCAR (Visual Average Speed Computer and Recorder), a stopwatch method of speed detection, may be in use.

Detector’s audible alerts become softer after the first few alerts.

Detector is in AutoMute mode. See “AutoMute” in the Settings & Preferences section for details.

The power-on sequence reoccurs while you are driving.

A loose power connection can cause MAX 4 to be briefly disconnected and will retrigger the power-on sequence. Check all connections.

You wish to restore the factory default settings.

Press and hold the MRK and BRT buttons while powering on the detector. A “Factory Settings Restored” message will display, acknowledging the reset.

The device will not turn on.

Check that vehicle ignition is on.

The display is blank.

MAX 4 is in Dark mode. Press the BRT button to adjust the brightness.



©2024 ESCORT Inc. ESCORT®, MAX 4®, Defender®, AutoLearn®, TrueLock™, AutoSensitivity™, SpecDisplay™, ExpertMeter™, IVT Filter™, SmartMute™ and EZ Mag Mount™ are trademarks of ESCORT, Inc.

Drive Smarter® is a registered trademark of Cedar Electronics Corporation.

Apple and the Apple logo are trademarks of Apple Inc. Registered in the U.S. and other countries. App Store is a service mark of Apple Inc. Android and Android Auto are trademarks of Google LLC. Compatible Android phone and compatible active data plan required. The Bluetooth® word mark and logos are registered trademarks of Bluetooth SIG, Inc. and any use of such marks by Cobra Electronics Corporation is under license. Features, Specifications and prices subject to change without notice.

FCC NOTE: Modifications not expressly approved by the manufacturer could void the user's FCC granted authority to operate the equipment.

FCC ID:QKLMX4

THIS DEVICE COMPLIES WITH PART 15 OF THE FCC RULES. OPERATION IS SUBJECT TO THE FOLLOWING TWO CONDITIONS: (1) THIS DEVICE MAY NOT CAUSE HARMFUL INTERFERENCE, AND (2) THIS DEVICE MUST ACCEPT ANY INTERFERENCE RECEIVED, INCLUDING INTERFERENCE THAT MAY CAUSE UNDESIRE OPERATION.

FCC Part 15.21 Warning Statement-

NOTE: THE GRANTEE IS NOT RESPONSIBLE FOR ANY CHANGES OR MODIFICATIONS NOT EXPRESSLY APPROVED BY THE PARTY RESPONSIBLE FOR COMPLIANCE. SUCH MODIFICATIONS COULD VOID THE USER'S AUTHORITY TO OPERATE THE EQUIPMENT.

FCC Part 15.105(b) Warning Statement- (ONLY Required for 15.109-JBP devices)

NOTE: This equipment has been tested and found to comply with the limits for a Class B digital device, pursuant to part 15 of the FCC Rules. These limits are designed to provide reasonable protection against harmful interference in a residential installation. This equipment generates uses and can radiate radio frequency energy and, if not installed and used in accordance with the instructions, may cause harmful interference to radio communications. However, there is no guarantee that interference will not occur in a particular installation. If this equipment does cause harmful interference to radio or television reception, which can be determined by turning the equipment off and on, the user is encouraged to try to correct the interference by one or more of the following measures:

- Reorient or relocate the receiving antenna.
- Increase the separation between the equipment and receiver.
- Connect the equipment into an outlet on a circuit different from that to which the receiver is connected.
- Consult the dealer or an experienced radio/TV technician for help

Warning:

This device should be installed and operated with minimum 20 cm between the radiator and your body.

DISPOSAL OF ELECTRONICS EQUIPMENT: This product may contain hazardous substances that could impact health and the environment if not disposed of properly.

The crossed out wheeled bin symbol indicates that the product should not be disposed of along with household waste. It should be handed over to an applicable collection point for the recycling of electrical equipment. By ensuring that this product is disposed of correctly you will help/prevent potential negative impact on the environment.



If you need more information on the collection, reuse and recycling systems, please contact your local civic office or the shop where it was originally purchased.



LIMITED 1-YEAR WARRANTY

Escort, Inc. ("Escort") warrants that this product and the component parts thereof, will be free of defects in workmanship and materials for a period of one year from the date of first consumer purchase. This warranty may be enforced by the first consumer purchaser. If the product is under warranty, it will be repaired or exchanged depending on the model as determined at Escort's sole discretion. Such remedy shall be your sole and exclusive remedy for any breach of warranty.

The procedure for obtaining service and support, and the applicability of this warranty, will vary depending on the country or jurisdiction in which you purchased and utilize the product. For the details on obtaining product service, support and warranty please visit <https://www.escortradar.com/pages/contact-us>

Provided that the product is utilized within the U.S.A.- Escort will, without charge, repair or replace, at its option, defective products, products or component parts upon delivery to the Escort Factory Service department, accompanied by proof of the date of first consumer purchase, such as a duplicated copy of a sales receipt. You must pay any initial shipping charges required to ship the product for warranty service, but the return charges, to an address in the U.S.A., will be at Escort's expense, if the product is repaired or replaced under warranty.

This warranty gives you specific legal rights, and you may also have other rights which may vary from state to state and country to country.

Exclusions: This limited warranty does not apply: 1) To any product damaged by accident; 2) In the event of misuse, ordinary wear, failure to follow directions, or improper maintenance of the product or as a result of unauthorized alterations or repairs; 3) If the serial number has been altered, defaced, or removed; 4) If the product was purchased or is utilized in a jurisdiction not covered by the limited warranty.

All implied warranties, including warranties of merchantability and fitness for a particular purpose are limited in duration to the length of this warranty. Escort shall not be liable for any incidental, consequential or other damages; including, without limitation, damages resulting from loss of use or cost of installation.

Some states and countries do not allow limitations on how long an implied warranty lasts and/or do not allow the exclusion or limitation of incidental or consequential damages, so the above limitations may not apply to you. This warranty gives you specific legal rights, and you may also have other rights which vary from state to state and country to country